

The Brose e-Bike System

Instructions for Use



Table of contents

Figures.....	4
Quick Start Instructions	6
Drive unit	7
Display and control unit	10
Battery pack	14
Battery charger	18
Troubleshooting.....	21
Your notes	23

1

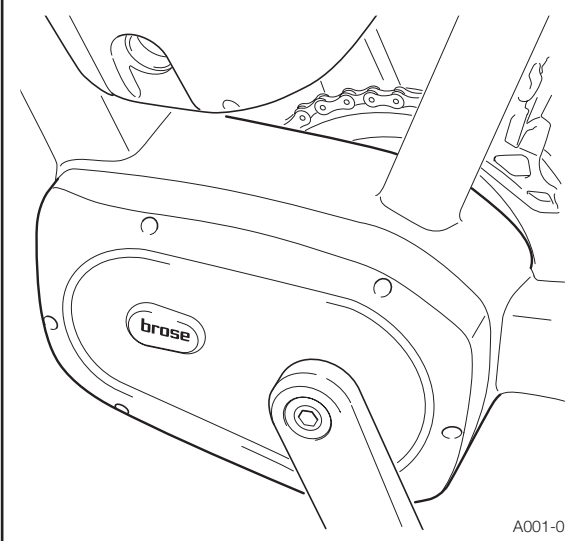

A001-0

2

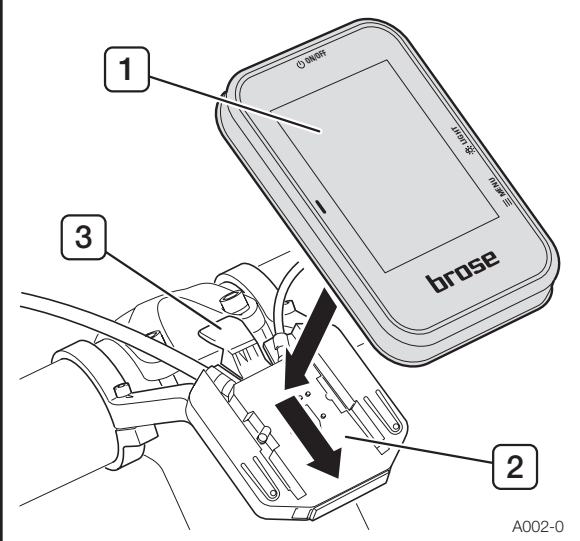

A002-0

3

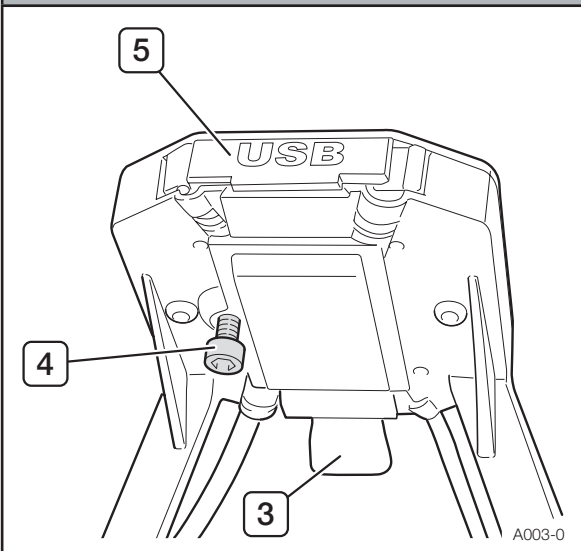

A003-0

4



A004-0

5

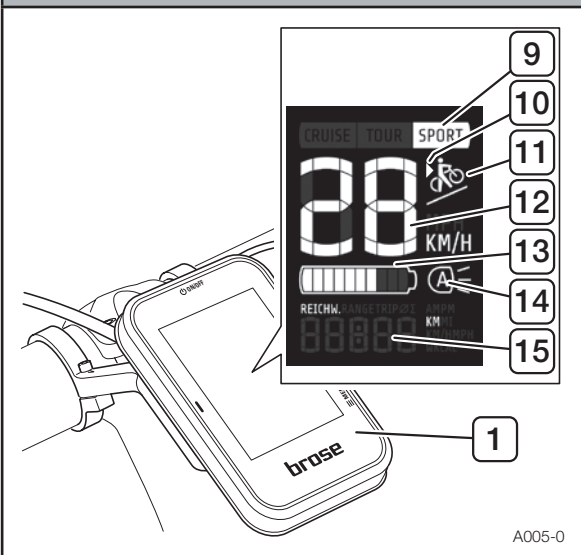

A005-0

6

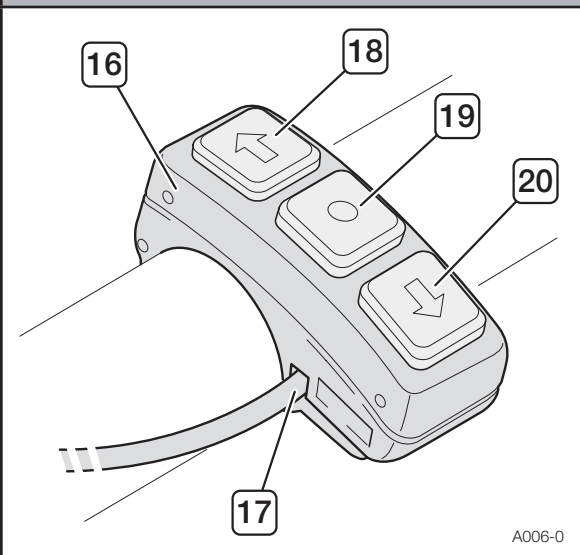

A006-0

7

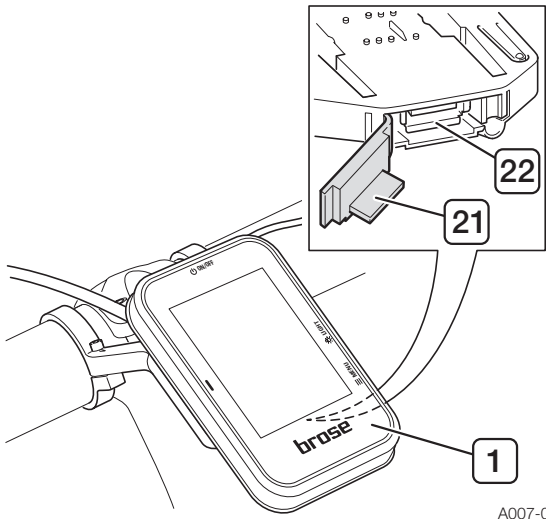

A007-0

8

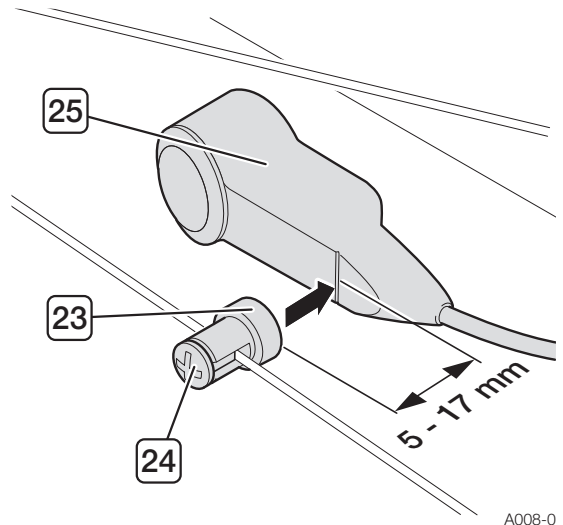

A008-0

9

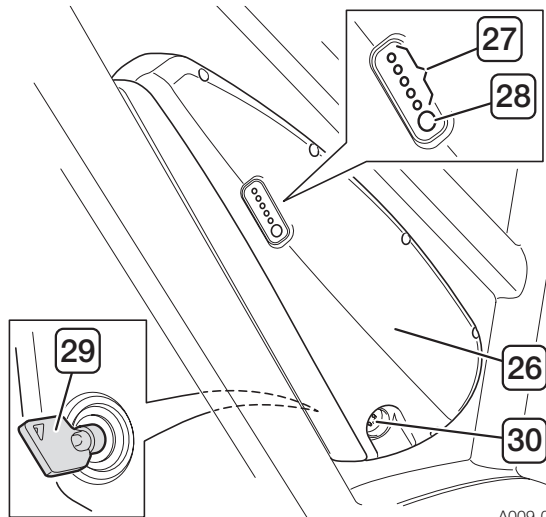

A009-0

10

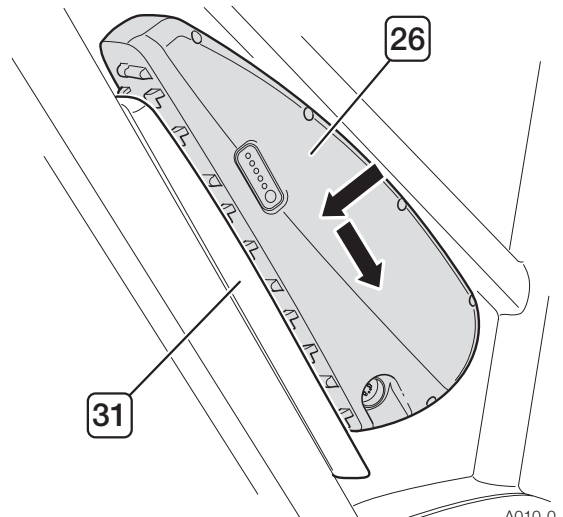

A010-0

11

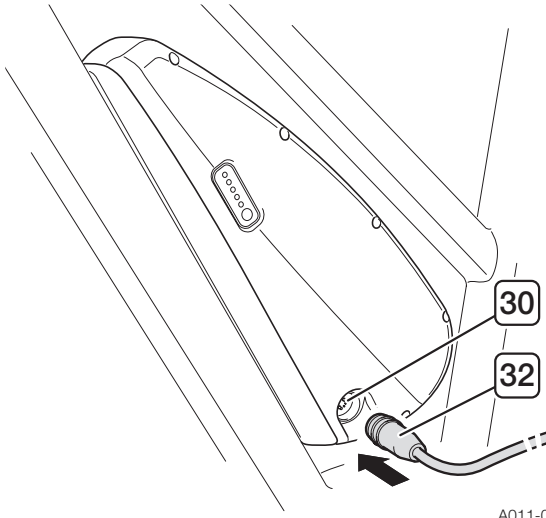

A011-0

12

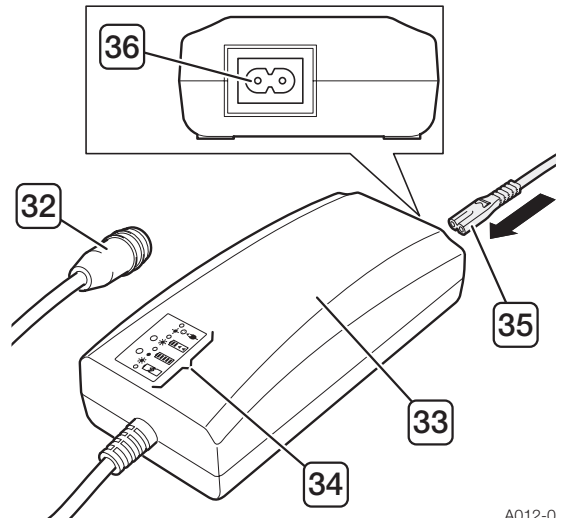

A012-0

Quick Start Instructions

This section summarizes for you all the important information and instructions enabling you to use your Brose e-Bike System as quickly as possible.

- Fully charge the battery pack (26) (see „Charging the battery pack“ on page 19)
- Insert the battery pack (26) (see „[Fig. 10] Inserting/removing the battery pack“ on page 15)
- Lock the battery pack key (29) (see Fig. 9 sowie „Locking/unlocking the battery pack key“ on page 15)
- Insert the display unit (1) (see „[Fig. 2] Inserting the display unit“ on page 10)
- Activate the Brose e-Bike System using the LED button (28) on the battery pack (26) (see Fig. 9 and also „Switching on the Brose e-Bike System“ on page 11)
 - The display unit (1) activates automatically
- Select the assist level using the control unit (16) (see Fig. 6 and also „Setting the assist level“ on page 12)
- The e-Bike is now ready to use.

Drive unit

Safety directions

- Please follow all safety directions and instructions found in both these Instructions for Use and in all other sets of instructions supplied with the e-Bike.
 - Not following these safety directions and instructions can lead to electric shocks, fires and/or severe injuries.
- Keep these Instructions for Use safe for future reference.
- The term “battery pack” used in these Instructions for Use equally relates to downtube-mounted battery packs, rack-mounted battery packs and frame-integrated battery packs.
- Never open the drive unit. It is maintenance-free and may only be repaired by qualified experts using only original spare parts.
 - This ensures the safety of the drive unit. All warranty claims are invalidated if the drive unit has been opened without authorization.
- All components forming part of the e-Bike System and parts fitted to the drive unit (e.g. chain ring, mounting of chain ring, pedals) may be replaced only by components approved by the manufacturer of the e-Bike.
 - This protects the drive unit from damage (e.g. due to overloading).
- Remove the battery pack (26) from the e-Bike before working on it (e.g. when fitting, servicing or working on the chain etc.), transporting it or placing it in storage.
 - There is a risk of injury if the e-Bike System is activated by mistake.
- The push-assist may only be used when the e-Bike is pushed.
 - There is a risk of injury if the wheels of the e-Bike are not in contact with the ground when the push-assist is used.
- Do not make any alterations at all to your e-Bike System. On no account attempt to improve the performance of your e-Bike System.
 - If you do so, you will shorten the service life of its components and run the risk of damaging both the e-Bike System and the e-Bike itself. Furthermore, the warranty and any warranty claims will be invalidated if there has been any type of manipulation of the e-Bike System. Incorrect handling of the e-Bike System also endangers both your own health and that of other road users. By making your own alterations to the e-Bike System, you run the risk of high personal liability costs or even criminal prosecution in the event of accidents due to manipulation.

- Please follow all national regulations relating to the licensing and use of e-Bikes.
- Please read and follow the safety directions and instructions in the Instructions for Use of the battery pack (26) and in the Instructions for Use of your e-Bike.

Use for the intended purpose

The drive unit is intended solely for powering your e-Bike and may not be used for any other purposes.

Key to illustrations

All illustrations are diagrammatical and hence may differ in some details from your e-Bike.

Fig.	Explanation
1	Drive unit with design covers and fitted cranks

Operation

For information on operating the Brose e-Bike System, please refer to the section on the display and control unit (see „Display and control unit“ on page 10).

N.B.: The Brose e-Bike System only operates when the display unit (1) has been inserted.

Cycling instructions and tips

When does the e-Bike drive operate?

The Brose e-Bike System permits electric motor assistance of the cyclist in a Pedal Electric Cycle (PEDELEC). This assistance depends on the force applied to the pedals by the cyclist. Assistance by the e-Bike drive is therefore only provided when the cyclist is pedaling. This applies regardless of the assist level.

The e-Bike drive switches off automatically at speeds of more than 25 km/h. If the speed drops below 25 km/h, the assist switches back on automatically.

An exception to this is the push-assist function, in which the e-Bike can be pushed more comfortably at low speed without pedaling. When the push-assist is used, the pedals can also turn.

You can also use the e-Bike at any time like a normal bike, without assistance, either by switching off the e-Bike System or setting the assist level to “OFF” (see „Setting the assist level“ on page 12). The same applies when the battery pack (26) is flat.

Familiarization

Take the time to get used to your Brose e-Bike System before venturing into normal traffic conditions. Test the various assist levels until you feel confident in handling the system. Before setting off on long trips, gain experience of how different parameters and ambient conditions affect the range of your e-Bike.

Motor setups

The Brose e-Bike System supports various motor setups. The following tells you more about the characteristics of the different settings.

Trekking:

The Trekking profile ensures balanced and continual assistance for longer trips.

City:

The City profile ensures speedy movement in city traffic thanks to a progressive delivery of power when starting off.

Mountainbike

The Mountainbike profile provides direct and maximum delivery of force for trips in difficult terrain and for steep inclines.

Motor Setup	Assist level in %		
	Cruise	Tour	Sport
Trekking	40	165	250
City	65	165	290
MTB	80	240	320

N.B.: The motor setup or assist level can differ in the various models. Detailed information on the motor setup of your e-Bike can be obtained from the bicycle manufacturer and bicycle dealer.

Effects on range

The range is affected by many factors, such as:

- Assist level
 - The higher the selected assist level in otherwise identical conditions, the shorter the range.
- Gear changing style
- Type of tire
- Tire pressure
- Age, standard of care and charge level of battery pack (26)
- Route type (slopes) and conditions (road surface)
- Weather conditions (e.g. head wind, ambient temperature etc.)
- Weight of e-Bike

- Payload.

Careful handling of the Brose e-Bike System

Take care with the temperatures at which the e-Bike components are operated and stored. Protect the drive unit, the display unit (1) and the battery pack (26) from extreme temperatures (e.g. due to intensive sunlight without ventilation to compensate). The components (particularly the battery pack (26)) might be damaged by extreme temperatures.

Loss of power in drive unit

To protect itself from overloading or overheating (e.g. during uphill cycling), the drive unit has an automatic power reduction function.

The drive unit first reduces its power to 50 %. If overloading persists, it switches off completely (see error code „44“ on page 22).

Maintenance & cleaning

Keep all the components of your e-Bike clean, in particular the contacts of the battery pack (26) and its mounting (31). Clean them carefully with a soft and dry cloth.

All components including the drive unit must not be dipped in water or cleaned using a high-pressure cleaner.

For servicing or repairs to the e-Bike, please contact an authorized bicycle dealer.

Inspection

For the drive unit, an inspection by a service center certified by Brose is mandatory after a distance covered of 15,000 km.

Information on the service center responsible for you is available from your cycle dealer.

Transport

When transporting a complete e-Bike, please follow the instructions for transporting battery packs (see „Transport“ on page 17).

Disposal

The drive unit, display and control unit, battery pack (26), speed sensor (25), accessories and packaging should be recycled in environment-friendly processes. Do not dispose of e-Bikes and their components as normal waste!

For EU countries only:



In line with the European Union directive 2012/19/EU, electrical appliances which are no longer serviceable must be collected separately and recycled in environment-friendly processes, and in line with directive 2006/66/EC the same applies for defective or used-up batteries.

Please hand in battery packs (26) and display units (1) which are no longer serviceable to an authorized bicycle dealer.

Specifications

Drive unit	
Brose Material number	C16162
Dimensions	213 x 150 x 128 mm
Weight	3.400 g
Rated voltage	36 V \equiv
Tightness	IP56
Torque max.	90 Nm
Continuous rated power	250 W
Assistance up to	25 km/h
Working temperature range	-10 to 50°C

Display and control unit

Safety directions

- Please follow all safety directions and instructions found in both these Instructions for Use and in all other sets of instructions supplied with the e-Bike.
 - Not following these safety directions and instructions can lead to electric shocks, fires and/or severe injuries.
- Keep these Instructions for Use safe for future reference.
- The term "battery pack" used in these Instructions for Use equally relates to downtube-mounted battery packs, rack-mounted battery packs and frame-integrated battery packs.
- Remove the battery pack (26) from the e-Bike before working on it (e.g. when fitting, servicing or working on the chain etc.), transporting it or placing it in storage.
 - There is a risk of injury if the e-Bike System is activated by mistake.
- The push-assist may only be used when the e-Bike is pushed.
 - There is a risk of injury if the wheels of the e-Bike are not in contact with the ground when the push-assist is used.

Use for the intended purpose

The display and control unit of the Brose e-Bike System is intended solely for use in the latter. It is used to display information relevant for cycling and status, and to control the drive unit.

Key to illustrations

The numbering of the components described relates to the illustrations on the picture pages at the beginning of these instructions (see page 4-5). All illustrations are diagrammatical and hence may differ in some details from your e-Bike.

Item	Fig.	Explanation
1	2/4/5/7	Display unit
2	2	Mounting of display unit
3	2/3	Unlocking button of mounting
4	3	Fastening bolt
5	3	Position of USB interface
6	4	Menu button
7	4	Light button
8	4	On/Off button
9	5	Display of assist level
10	5	Display of push-assist
11	5	Display of cycling speed
12	5	Display of battery pack charge level

Item	Fig.	Explanation
13	5	Display of light mode
14	5	Display of multifunctional panel
15	6	Control unit
16	6	Cable routing of control unit
17	6	"Raise assist level" button
18	6	multifunctional panel button
19	6	"Lower assist level" button
20	7	Cover cap of USB interface
21	7	USB interface
22	8	Spoke magnet
23	8	Fastening bolt of spoke magnet
24	8	Speed sensor

Assembly

[Fig. 2] Inserting the display unit

- Insert the display unit (1) with the guide groove on the rear face into the guide opening of the mounting (2).
- Slide the display unit (1) all the way down until you hear it snap into place.

[Fig. 3] Removal preventer

The mounting (2) has an optional removal preventer.

- Where applicable, screw the fastening bolt (4) lightly from underneath into the mounting (2) once the display unit (1) is in place.

Removing the display unit

- Deactivate the display unit (1) before removing it from the mounting (2).
- Undo the fastening bolt (4), where applicable.
- Keep the unlocking button (3) pressed down and push the display unit (1) upwards inside its guide opening until it can be removed from the mounting (2).

N.B.: An integrated memory ensures that your data (e.g. clock time, kilometers per day, cycling time etc.) are saved when the display unit (1) is removed.

Putting into service

Putting the display and control unit into service does not require any further steps after assembly. The display and control unit is ready to operate as soon as it has been correctly inserted into the mounting (2).

N.B.: Full functioning is only possible when the speed sensor (25) and the cables have been correctly fitted and the battery pack (26) sufficiently charged.

Operation

Once the display unit (1) is in place inside the mounting (2), a battery pack (26) with sufficient charge has been inserted into the e-Bike and the e-Bike System has been switched on, the display unit (1) is supplied with power by the battery pack (26).

N.B.: The display unit (1) does not have its own battery and so cannot be used or operated outside of its mounting (2).

N.B.: As soon as the battery pack (26) is in "Active Mode", the display unit (1) always remains switched on during cycling, even if the motor assist has been deactivated.

Switching on the Brose e-Bike System

- Press the LED button (28) on the battery pack (26).
 - The display unit (1) activates automatically.
 - The e-Bike is now ready to use.

N.B.: Directly after switch-on, the software version number of the display unit (1) briefly appears in the multifunctional panel (15).

Switching off the Brose e-Bike System

Standby mode

If the e-Bike is not moving, the display unit (1) and the drive unit switch to a standby mode. This can however also be activated manually.

If you want to park your e-Bike only for a short period, this is how you switch to the standby mode:

- Press the On/Off button (8) briefly (< 2 seconds).
 - This switches off the display unit (1) and the drive unit.
 - The battery pack (26) remains in the "Active Mode" for two hours (see „Operating modes of battery pack“ on page 16).
- As soon as you move your e-Bike again, the display and the drive unit are re-activated and the Brose e-Bike System is ready to use again.
- After 2 hours in the "Active Mode", the battery pack (26) goes into the "Deep Sleep Mode" (see „Operating modes of battery pack“ on page 16).

Complete switch-off

There are two ways to switch off the Brose e-Bike System completely:

- Press the On/Off button (8) for a long time (< 2 seconds).

OR

- Press the LED button (28) on the battery pack (26) for a long time (< 3 seconds).
 - This display unit (1), the drive unit and the battery pack (26) are completely switched off.

N.B.: For reactivation after complete switch-off, the system must be restarted using the LED button (28) on the battery pack (26) (see „Switching battery pack on and off“ on page 16).

[Fig. 5] Displays and settings

The display unit (1) shows various useful information:

- selected assist level (9)
- activity of push-assist (11)
- current cycling speed (12)
- current charge level of battery pack (13) in 10-percent increments
- light mode (14)
- multifunctional panel (15)

Background lighting

The background lighting is activated for 2 seconds whenever a button is pressed. The brightness here is 100 %.

At night, the background lighting is active all the time. The brightness is much lower here so that the cyclist is not dazzled. Brightness is regulated depending on the ambient light.

Battery charge and remaining range

The charge level (13) of the battery pack is shown in the display of the display unit (1) with 10 segments. One segment here corresponds to about 10 % of the battery capacity (see „Charge level display“ on page 15).

Display change in multifunctional panel (15)

- Press the menu button (6) on the display unit to switch between the functions of the multifunctional panel (15).

The multifunctional panel (15) presents the following information:

- Clock time
- Trip distance
- Trip calories
- Trip time
- Trip average speed
- Total kilometers
- Total time
- Pedal resistance

Changing over the measurement units

- Switch off the display unit (1) using the On/Off button (8) (press it briefly for < 2 s).
- Press the On/Off button (8) and the menu button (6) simultaneously for > 3 s until the software version of the display unit (1) appears in the multifunctional panel (15).
 - All displayed units are changed over between “km” and “mi” and “km/h” and “mph” respectively.

Setting the clock time

- In the multifunctional panel (15), change to the display of the clock time by pressing the menu button (6).
- Press the menu button (6) for > 2 s.
 - The hour display flashes.
- Set the hour display using the buttons “Raise assist level” (18) and “Lower assist level” (20).
- Confirm your entry using the menu button (6) or the multifunctional panel button (19).
 - The minute display flashes.
- Set the minute display using the buttons “Raise assist level” (18) and “Lower assist level” (20).
- Confirm your entry and leave the menu using the menu button (6) or the multifunctional panel button (19).

Reset trip functions

To reset the displayed values of the trip functions in the multifunctional panel (15), proceed as follows:

- Select any trip function by pressing the menu button (6).
- Press the menu button (6) for > 2 seconds.
 - All displayed values of the trip functions are reset to 0.

Reset total time

To reset the displayed value of the “Total time” function in the multifunctional panel (15), proceed as follows:

- Select the “Total time” function by pressing the menu button (6).
- Press the menu button (6) for > 2 seconds.
 - The displayed value of the “Total time” function is reset to 0.

Basic functions

Your Brose e-Bike System has three assist levels (9). Their characteristics are set out in the following table:

Description	
Off	No motor assist. At the same time, cycling without any resistance.
Cruise	Cyclist dominates, with perceptible assistance by the motor.
Tour	Motor enhances the strength of the cyclist over-proportionally (and yet sustainably).
Sport	Full delivery of the motor force with little effort by the cyclist.

Setting the assist level

- Press the button “Raise assist level” (18) on the control unit (16) to increase the assist level from OFF to SPORT.
- Press the button “Lower assist level” (20) on the control unit (16) to reduce the assist level from SPORT to OFF.

N.B.: If the control unit (16) on your e-Bike has been installed reversed by 180°, then the button functions of items 18 and 20 are reversed. It is always the button with the arrow pointing in the cycling direction that raises the assist level.

Activating/deactivating the push-assist

The push-assist (11) is used for assistance when pushing the e-Bike. It is activated as follows:

- Switch the assist level to “OFF” to activate the push-assist (11).
 - The arrow (10) is activated in the display of the display unit (1) and signals that the push-assist (11) is ready to operate.
- Press the button “Lower assist level” (20) down for > 1 second to activate the push-assist (11).
 - This activates the symbol for the push-assist (11) in the display unit (1).
 - The e-Bike accelerates without pedal assist to a manufacturer-specified speed of between 3 and 6 km/h
- Release the button “Lower assist level” (20) to deactivate the push-assist (11).

Expanded functions

Light mode (14)

You can switch the lighting on or off manually, or select the Automatic mode that automatically activates and deactivates the lighting depending on the ambient brightness.

- Press the light button (7) to switch the light on or off.
- Press the light button (7) for > 2 seconds to switch the Automatic mode on or off.

- An “A” inside the light symbol (14) comes on or goes out.

[Fig. 7] Power supply via USB interface

External devices can be supplied with power and charged using the Type A USB interface (22) integrated into the mounting (2).

- Insert the display unit (1) into the mounting (2).
- Open the cover cap (21) of the USB interface (22).
- Use a suitable USB cable to make the connection between the USB interface (22) and the required end device.
- If the connection is successful, the display “CHARG” briefly appears in the display unit (1).

Maintenance & cleaning

Keep all the components of your e-Bike clean, in particular the contacts of the battery pack (26) and its mounting (31). Clean them carefully with a soft and dry cloth.

All components including the drive unit must not be dipped in water or cleaned using a high-pressure cleaner.

For servicing or repairs to the e-Bike, please contact an authorized bicycle dealer.

Disposal

The drive unit, display and control unit, battery pack (26), speed sensor (25), accessories and packaging should be recycled in environment-friendly processes. Do not dispose of e-Bikes and their components as normal waste!

For EU countries only:



In line with the European Union directive 2012/19/EU, electrical appliances which are no longer serviceable must be collected separately and recycled in environment-friendly processes, and in line with directive 2006/66/EC the same applies for defective or used-up batteries.

Please hand in battery packs (26) and display units (1) which are no longer serviceable to an authorized bicycle dealer.

Specifications

Display and control unit	
Brose Material No. Display unit	C54764
Brose Material No. Control unit	C54760
Dimensions of display unit	44,0 x 62,5 x 8,0 mm
Dimensions of display area	38,0 x 50,0 mm
Dimensions of control unit	18,0 x 46,0 x 19,75 mm
Weight of display unit	67 g
Tightness	IP65
Working temperature range	-10 to 60°C
Storage temperature range	-20 to 85°C
USB charge voltage	5 V $\overline{=}$
USB charge current max.	500 mA

Lights	
Rated voltage	6 V $\overline{=}$
Rated output*	
- Front light	2,6 W
- Rear light	0,6 W

* The rated power of the lights can differ depending on the battery pack model used. Detailed information can be obtained from the bicycle manufacturer and your bicycle dealer.

Battery pack

Safety directions

- Please follow all safety directions and instructions found in both these Instructions for Use and in all other sets of instructions supplied with the e-Bike.
 - Not following these safety directions and instructions can lead to electric shocks, fires and/or severe injuries. Injury and/or damage are also possible as a result of dangerous reactions of chemical substances leaking out of the battery pack (26) due to a failure to follow the safety directions.
- Keep these Instructions for Use safe for future reference.
- The term "battery pack" used in these Instructions for Use equally relates to downtube-mounted battery packs, rack-mounted battery packs and frame-integrated battery packs.
- Remove the battery pack (26) from the e-bike before working on the latter (e.g. when fitting, servicing or working on the chain etc.), transporting it, placing it in storage or not using it for a lengthy period.
 - There is a risk of injury if the e-Bike System is activated by mistake.
- Do not open, take apart or break up the battery pack (26).
 - There is a risk of a short-circuit. If the battery pack (26) is opened, this invalidates all warranty claims.
- Protect the battery pack (26) from heat (e.g. also from continual sunlight), fire and immersion in water.
 - This creates an explosion risk.
- Keep all metal objects (e.g. paper clips, nails, screws, keys etc.) well clear of the stored battery pack (26): they could cause bridging of the contacts.
 - A short-circuit can lead to burns or fires. If short-circuit damage results in this context, any claim for warranty by Brose is invalidated.
- Fluid can leak out of the battery pack (26) if the latter is not used correctly. Avoid any contact with this fluid. If contact does occur, rinse off the affected parts of the body with water. If the fluid contacts any sensitive membranes (e.g. eye), please also consult a doctor without delay.
 - Leaking battery fluid can cause skin irritation or burns.
- Battery packs (26) must not be subjected to any mechanical impacts.
 - There is a risk of the battery pack (26) being damaged.
- On no account continue to use any battery packs (26) which are defective or damaged.
 - There is an increased risk of short-circuits, fires or electric shocks.

- If the battery pack (26) is damaged or used incorrectly, vapors may be emitted. Let in plenty of fresh air, and consult a doctor if you suffer from any complaint.
 - These vapors can irritate the airways.
- Charge the battery pack (26) using only the battery charger (33) supplied with your Brose e-Bike System.
 - If other chargers are used, a risk of fire cannot be ruled out.
- Use the battery pack (26) only in conjunction with e-Bikes using the original Brose e-Bike System.
 - This is the only way to protect the battery pack (26) from dangerous overloading.
- Only use battery packs (26) approved by the cycle manufacturer for your e-Bike.
 - Using other battery packs can lead to injury and/or fire risk. If other battery packs are used, Brose shall not assume any liability or warranty.
- Please read and follow the safety directions and instructions found in both these instructions for use of all components of the e-bike systems and the instructions for use of your e-bike.
- Keep the battery pack (26) away from children.
- Always keep the battery pack (26) clean and dry.
- Always ensure that the contacts of the battery pack (26) are clean. If they are fouled, clean them with a dry cloth.
- Avoid unnecessary charging. Do not charge the battery pack (26) over a long period if you do not use it.
- Never leave the battery pack (26) and battery charger (33) unattended during charging.

Use for the intended purpose

The battery pack (26) is designed and intended only for use in a Brose e-Bike System.

Key to illustrations

The numbering of the components described relates to the illustrations on the picture pages at the beginning of the instructions.

N.B.: All illustrations are diagrammatical and serve as examples. They may differ in some details from your e-Bike, since the Brose e-Bike System can be combined with a large number of different battery pack variants. Detailed information on the battery pack (26) used in your e-Bike can be obtained from your bicycle dealer and the cycle manufacturer.

Item	Fig.	Explanation
25	9/10	Battery pack
26	9	Charge level display
27	9	LED button
28	9	Integrated lock
29	9/11	Charging socket
30	10	Mounting rail

Assembly

[Fig. 10] Inserting/removing the battery pack

The Brose e-Bike System can be combined with a large number of different battery pack variants. Fitting and removal of the battery pack (26) depend on the battery pack model used. Detailed information on this can be obtained from your bicycle dealer and the bicycle manufacturer.

N.B.: Always switch off the battery pack (26) before inserting it into the mounting (31) or removing it from the latter.

Locking/unlocking the battery pack key

The different assembly variants of the battery pack (26) also entail different variants of the battery pack key (29).

Detailed information on locking/unlocking the battery pack (26) can be obtained from your bicycle dealer and the bicycle manufacturer.

Putting into service

Testing the battery pack before its first use

The battery pack (26) is supplied partially charged. For that reason, test the battery pack (26) before charging it for the first time or using it with your e-Bike.

- Press the LED button (28) to switch on the battery pack (26).
 - The charge level display (27) should now light up between “empty” and “full” and then display the current charge level for about 4 seconds.
 - If no LED in the charge level display (27) comes on and the battery pack (26) cannot be activated, it may be that the cell voltage is too low and the battery pack (26) needs to be charged.
 - If at least one but not all LEDs of the charge level display (27) comes on, the battery pack (26) should be fully charged before it is first used.

[Fig. 11] Charging the battery pack

Use only the battery charger (33) supplied with your e-Bike. Only this charger is matched to the lithium-ion battery pack (26) used in your e-Bike.

N.B.: The battery pack (26) is supplied partially charged (approx. 30-50 %). To ensure full power from the battery pack (26), fully charge it before its first use using the battery charger (33) (see also „Battery charger“ on page 18).

The battery pack (26) can be charged at any time, either separately or on the e-Bike, without shortening its service life.

- Connect the battery charger (33) to the mains.
 - The LED status display (34) of the battery charger (33) should now be active (see „LED status displays“ on page 19).

Battery pack not on e-Bike:

- Connect the charging plug (32) of the battery charger (33) to the charging socket (30) of the battery pack (26).
 - The charging operation begins.

N.B.: Some battery packs (26) can be provided with two charging sockets (30). It is not important which of the two sockets (30) you use for charging.

Battery pack on e-Bike:

- Connect the charging plug (32) of the battery charger (33) to the vacant charging socket (30) of the battery pack (26).
 - The charging operation begins.

N.B.: Interrupting the charging operation does not damage the battery pack (26).

N.B.: If the battery pack (26) does not recharge, then the cell voltage has fallen below the critical value of 2 V per cell and the battery pack (26) is defective.

N.B.: Do not charge a damaged battery pack (26) and do not use it. Please contact an authorized bicycle dealer.

N.B.: The battery pack (26) attains its maximum service life when it is charged at ambient temperatures between 10 and 30 °C.

Charge level display

The five LEDs of the charge level display (27) show the charge level of the battery pack (26) when the LED

button (28) is pressed. Each LED here corresponds to about 20 % of capacity. When the battery pack (26) is fully charged, all five LEDs light up. The charge level of the switched-on battery pack (26) is also shown on the display in the display unit (1) (see „Battery charge and remaining range“ on page 11). If the capacity of the battery pack (26) is below 10 %, the first LED of the charge level display (27) flashes.

The battery pack (26) can be charged with and without the display unit (1). Without the display unit (1), the charging operation can only be tracked at the charge level display (27) of the battery pack (26). The display unit (1) can be removed during charging or fitted only after the charging operation has started. The charge level is indicated by the charge level display (27) on the battery pack (26) and by the bar (13) on the display unit. During charging, the LEDs of the charge level display (27) on the battery pack (26) light up. Each steady LED corresponds to about 20 % of capacity. The flashing LED shows the charging of the next 20 %.

During charging, the charge level display (27) is as follows:

LED steady	LED flashing	Charge level
-	1	0-19 %
1	2	20-39 %
1, 2	3	40-59 %
1, 2, 3	4	60-79 %
1, 2, 3, 4	5	80-99 %
1, 2, 3, 4, 5	-	End of charging, battery pack 100 % charged

Operation

Switching battery pack on and off

Switching on the battery pack (26) is one of the options for switching on the Brose e-Bike System.

- Press the LED button (28) on the battery pack (26).
 - The LEDs of the charge level display (27) come on briefly and then show the current charge level for about 4 seconds.

N.B.: If the capacity of the battery pack (26) is below 10 %, only the first LED of the charge level display (27) flashes.

- To switch off the battery pack (26), press the LED button (28) for > 3 seconds.
 - The LEDs of the charge level display (27) go out.
 - The e-Bike System too is also switched off.

Operating modes of battery pack

Active Mode

After switch-on, the battery pack (26) is in the “Active Mode”. It remains in the “Active Mode” for 2 hours without any further action (operation or movement of the e-Bike).

The “Active Mode” is activated by operating the LED button (28), by charging the battery pack (26), or by inserting the battery pack (26) into the e-Bike.

Deep Sleep Mode

To minimize the power consumed by the system itself, the battery pack (26) switches automatically to the “Deep Sleep Mode” after 2 hours in the “Active Mode” without any activity and with the display unit (1) switched off. The “Deep Sleep Mode” is also activated when the LED button (28) or the On/Off button (8) of the display unit (1) is pressed for > 3 seconds or when the battery pack (26) is not inserted into the e-Bike for longer than 30 seconds.

Power reduction of battery pack

For self-protection against overloading or overheating, the battery pack (26) has a function for automatic power reduction depending on the charge level and temperature.

Above a cell temperature of 70°C, and between 0 and 10°C, the motor power is reduced in 4 stages (25 % each) until the drive is switched off.

With a charge level of < 5 %, the drive assist is switched off, so that the display unit (1) and the lights can be operated for at least 4 more hours before the battery pack (26) deactivates for self-protection.

Maintenance, cleaning and storage

Keep the battery pack (26) clean. Clean it carefully with a soft and dry cloth. The battery pack (26) must not be immersed in water or cleaned using a water jet. If the battery pack (26) is no longer working, please contact an authorized bicycle dealer. Set down the battery pack (26) only on clean surfaces. Avoid in particular any fouling of the charging sockets (30) and of the contacts.

The service life of the battery pack (26) can be extended if it is looked after well and above all stored in the right conditions:

Temperature	18-23°C
Humidity	0-80 %
Charge level	70 %

As the battery pack (26) gets older, its capacity will diminish even when it is looked after well. A considerably shorter operating time after charging indicates that the battery pack (26) is used up. You should then replace it.

Recharging the battery pack during storage

Check the charge level of the battery pack (26) after it has been in storage for around 3 months, and recharge it to about 60-79 % if necessary.

Transport

The battery pack (26) may only be dispatched in packaging suitable for hazardous goods and provided with the necessary warning notices.

If you have any questions about transport, please contact an authorized bicycle dealer. The dealer can also provide you with suitable transport packaging.

Disposal

The drive unit, display and control unit, battery pack (26), speed sensor (25), accessories and packaging should be recycled in environment-friendly processes. Do not dispose of e-Bikes and their components as normal waste!

For EU countries only:



In line with the European Union directive 2012/19/EU electrical appliances which are no longer serviceable must be collected separately and recycled in environment-friendly processes, and in line with directive 2006/66/EC the same applies for defective or used-up batteries.

Please hand in battery packs (26) and display units (1) which are no longer serviceable to an authorized bicycle dealer.

Specifications

You will find detailed information on the specifications of the battery pack (26) used in your e-Bike in the data sheet supplied by the bicycle manufacturer.

Battery pack	
Battery technology	Lithium ions
Rated output voltage	36 V \equiv
Cell configuration	10S4P (40 cells) or 10S5P (50 cells)
Capacity	Variable

Battery charger

Safety directions

- Please follow all safety directions and instructions found in both these Instructions for Use and in all other sets of instructions supplied with the e-Bike.
 - Not following these safety directions and instructions can lead to electric shocks, fires and/or severe injuries.
- Keep these Instructions for Use safe for future reference.
- The term "battery pack" used in these Instructions for Use equally relates to downtube-mounted battery packs, rack-mounted battery packs and frame-integrated battery packs.
- Never expose the battery charger (33) to heavy moisture (e.g. rain, snow etc.).
 - If water gets into the battery charger (33), there is a risk of electric shock.
- Only charge the lithium-ion battery pack (26) supplied for your Brose e-Bike System. Battery voltage and charge voltage of the battery charger (33) must match.
 - Otherwise there is a risk of fire and explosion.
- Always keep the battery charger (33) clean.
 - Fouling leads to a risk of electric shock.
- Check the battery charger (33), cables and plugs every time before using them. If you discover any damage, on no account use the battery charger (33). Do not open the battery charger (33), and have it repaired only by qualified experts using only original spare parts.
 - Damaged battery chargers (33), cables and plugs increase the risk of an electric shock.
- Do not operate the battery charger (33) on easily inflammable surfaces (e.g. paper, textiles etc.) or in inflammable surroundings.
 - The heating up of the battery charger (33) during charging creates a fire risk.
- Children and persons unable to safely operate the battery charger (33) due to lower physical, sensory or mental capacities or their inexperience or their lack of knowledge, may not use the charger without supervision or instruction by a responsible adult.
 - Failing that, there is a risk of incorrect operation and injury.
- Please read and follow the safety directions and instructions found in both the Instructions for Use of the battery pack (26) and of the drive unit/display unit and in the Instructions for Use of your e-Bike.
- The underside of the battery charger (33) is provided with a brief version of important safety directions in English, French and Spanish stating the following:
 - For safe use please follow the Instructions for Use. Risk of electric shock.

- Only use in dry surroundings.
- Only charge battery packs (26) of the Brose e-Bike System. Other battery packs (26) might explode and cause injury.
- Do not replace the mains cable. There is a risk of fire and explosion.
- Never leave the battery pack (26) and battery charger (33) unattended during charging.

Use for the intended purpose

The battery charger (33) must be used exclusively for charging the battery pack (26) supplied with the Brose e-Bike System.

Key to illustrations

The numbering of the components described relates to the illustrations on the picture pages at the beginning of the instructions.

N.B.: All illustrations are diagrammatical and serve as examples. They may differ in some details from your e-Bike, since the Brose e-Bike System can be combined with various battery chargers (33). Detailed information on the battery charger (33) supplied with your e-Bike can be obtained from your bicycle dealer and the bicycle manufacturer.

Item	Fig.	Explanation
31	11/12	Charge plug
32	12	Battery charger
33	12	LED status display
34	12	Mains connection plug
35	12	Mains connection

Putting into service

[Fig. 12] Connecting the battery charger to the mains

N.B.: Ensure the correct mains voltage! The voltage of the power source must match the specifications on the rating plate of the battery charger (33)

- Connect the mains connection plug (35) to the battery charger (33).
- Connect the battery charger (33) to the mains by plugging the mains cable into a suitable socket.
 - The LED status display (34) of the battery charger (33) should now be active.
 - The battery charger (33) is now ready to operate.

Operation

Charging the battery pack

- Charge the battery pack (26) only when all safety directions are followed.

Charging the removed battery pack

- Switch off the battery pack (26) (see „Switching battery pack on and off“ on page 16).
- Remove the battery pack (26) from the mounting (31) on the e-Bike (see „[Fig. 10] Inserting/removing the battery pack“ on page 15).

N.B.: Set down the battery pack (26) only on clean surfaces. Avoid in particular any fouling of the charging sockets (30) and of the contacts.

- Insert the charging plug (32) of the battery charger (33) into one of the two charging sockets (30) on the battery pack (26).
 - The charging operation begins.

[Fig. 11] Charging the battery packs on the e-Bike

- Switch off the battery pack (26).
- Insert the charging plug (32) into the vacant charging socket (30) on the battery pack (26).
 - The charging operation begins.

N.B.: Avoid any fouling of the charging sockets (30) and of the contacts.

Charging in progress

Charging begins automatically as soon as the battery charger (33) has been connected to the battery pack (26) and the mains.

The battery pack (26) can be charged with and without the display unit (1). Without the display unit (1), the charging operation can only be tracked at the charge level display (27) of the battery pack (26). The display unit (1) can be removed during charging or fitted only after the charging operation has started. The charge level is indicated by the charge level display (27) on the battery pack (26) and by the bar (13) on the display unit (1). During charging, the LEDs of the charge level display (27) on the battery pack (26) come on (see „Charge level display“ on page 15).

N.B.: Be careful when you touch the battery charger (33) during charging. It can become very hot, particularly in high ambient temperatures.

Once the battery pack (26) is fully charged, the LEDs go out immediately. The charging operation is terminated.

- Disconnect the battery charger (33) from the mains.
- Disconnect the battery pack (26) from the battery charger (33).
 - This switches off the battery pack (26) automatically.

If the battery pack (26) is not disconnected from the battery charger (33) after charging and the battery charger (33) remains connected to the mains, it will switch back on after a few hours, check the charge state of the battery pack (26), and if necessary begin another charging operation.

LED status displays	
Battery charger 2 A	
Standby	green LED steady
Pre-charge	green and red LEDs flashing
Charging in progress	red LED steady
battery pack full / trickle charge	green LED steady
Battery test	green LED steady

Battery charger 4 A	
Standby	Green LED flashing
Charging in progress	red LED steady
battery pack full / trickle charge	green LED steady
Error	green and red LEDs flashing

Maintenance & cleaning

If the battery charger (33) is no longer serviceable, please contact an authorized bicycle dealer.

Use a soft and dry cloth to clean the battery charger. Do not use water or any other cleaning fluids!

Disposal

Battery chargers (33), accessories and packaging should be recycled in environment-friendly processes. Do not dispose of battery chargers (33) as normal waste!

For EU countries only:



In line with European Directive 2012/19/ EU on waste electrical and electronic equipment and its implementation in national law, chargers which are no longer usable must be collected separately and recycled in environment-friendly processes.

Specifications

The Brose e-Bike System can be combined with a large number of battery chargers (33). Detailed information on your model can be obtained from your bicycle dealer and the bicycle manufacturer.

Battery charger 2 A	
Dimensions	140,0 x 70,0 x 40,0 mm
Weight	475 g
End-of-charge voltage	42 V $\overline{=}$
Rated output current	2 A
Working temperature range	-10 to 40°C
Storage temperature range	-20 to 70°C

Battery charger 4 A	
Dimensions	206,0 x 94,0 x 61,0 mm
Weight	770 g
End-of-charge voltage	42 V $\overline{=}$
Rated output current	4 A
Working temperature range	0 to 45°C
Storage temperature range	-25 to 70°C

Troubleshooting

If any problems occur during use of your Brose e-Bike System, first of all check them off against those listed in the table. This will enable you to solve the problem yourself in many cases.

Symptom	Possible cause	Solution approach
Display unit (1) and/or Brose e-Bike System cannot be activated.	Malfunction of battery pack (26) despite full charge	Press the LED button (28) to check whether the battery pack can be switched on. The LEDs of the charge level display (27) on the battery pack (26) should come on. If this is not the case, there may be a defect in the battery pack (26).
	Battery pack (26) not correctly snapped into mounting (31)	Remove the battery pack (26) again and then re-insert it. Ensure that it is seated correctly.
	Battery pack (26) not charged	Complete a charging operation using the supplied battery charger (33).
	Contacts of battery pack (26) and/or of mounting (31) fouled	Check that all contacts are clean. If necessary clean them with a soft and dry cloth.
	Display unit (1) not correctly snapped into mounting (2)	Remove the display unit (1) again and then re-insert it. Ensure that it is seated correctly.
	Contacts of display unit (1) and/or of mounting (2) fouled	Check that all contacts are clean. If necessary clean them with a soft and dry cloth.
	Plug connections at the drive unit not correctly inserted	Check the cables and plug connections, and connect them properly where necessary.
Display unit (1) not supplying cycling data even though the e-Bike is in motion.	Spoke magnet (23) not correctly fitted (distance from speed sensor (25))	Check the fitting of the spoke magnet (23), particularly its distance from the speed sensor (25) on the chain stay. This distance must be between 5 and 17 mm (see Fig. 8). Correct the distance where necessary.
Bike lights cannot be activated.	Cable for lights incorrectly connected	Check the cables and plug connections, and connect them properly where necessary.
Display unit (1) displays an error code in the multifunctional panel (15).	There is an active error in the system.	Please refer to the following table

Error codes

You can see from the following table which error is present in the system and what can be done when your display unit (1) displays an error code.

Error code	Description	Solution approach
10	The battery voltage is too low.	Charge the battery pack (26) using the battery charger (33).
11	The battery voltage is too high.	Switch off the system completely and then back on using the LED button (28) on the battery pack (26). If the problem persists, contact your e-Bike dealer.
12	The battery is almost/completely discharged	Charge the battery pack (26) using the battery charger (33).
20	Electrical measurements are faulty.	Switch off the system completely and then back on using the LED button (28) on the battery pack (26). If the problem persists, contact your e-Bike dealer.
21	Thermo sensor defective	Switch off the system completely and then back on using the LED button (28) on the battery pack (26). If the problem persists, contact your e-Bike dealer.
23	Thermo sensor defective	Switch off the system completely and then back on using the LED button (28) on the battery pack (26). If the problem persists, contact your e-Bike dealer.
24	The internal voltage is outside the working range.	Charge the battery pack (26) using the battery charger (33).
25	Error in motor current measurement	Switch off the system completely and then back on using the LED button (28) on the battery pack (26). If the problem persists, contact your e-Bike dealer.
26	A software reset has been performed	Switch off the system completely and then back on using the LED button (28) on the battery pack (26). If the problem persists, contact your e-Bike dealer.

Error code	Description	Solution approach
30	Error in push-assist	Switch off the system completely and then back on using the LED button (28) on the battery pack (26). If the problem persists, contact your e-Bike dealer.
40	Over-current detected in motor	Reduce the load on the motor by pedaling less or by reducing the assist level.
41	Over-current detected in motor	Reduce the load on the motor by pedaling less.
42	Fault in motor turning	Switch off the system completely and then back on using the LED button (28) on the battery pack (26). If the problem persists, contact your e-Bike dealer.
43	Short-circuit in motor	Switch off the system completely and then back on using the LED button (28) on the battery pack (26). If the problem persists, contact your e-Bike dealer.
44	Overheating of motor	Reduce the load on the motor by pedaling less or by reducing the assist level.
45	The software has corrected an error during turning of the motor	Switch off the system completely and then back on using the LED button (28) on the battery pack (26). If the problem persists, contact your e-Bike dealer.
46	No motor movement detected although a current of > 2 A was measured	Switch off the system completely and then back on using the LED button (28) on the battery pack (26). If the problem persists, contact your e-Bike dealer.
60	Interruption of data exchange on the CAN BUS	Check the cables and plug connections of all components of the e-Bike System.
70	Force applied to pedal not in valid range	Switch off the system completely and then back on using the LED button (28) on the battery pack (26). If the problem persists, contact your e-Bike dealer.
71	Turning of pedals not detected	Switch off the system completely and then back on using the LED button (28) on the battery pack (26). If the problem persists, contact your e-Bike dealer.
72	Force applied to pedal not detected	Switch off the system completely and then back on using the LED button (28) on the battery pack (26). If the problem persists, contact your e-Bike dealer.
73	Fault in link to pedal force sensor	Switch off the system completely and then back on using the LED button (28) on the battery pack (26). If the problem persists, contact your e-Bike dealer.
80	Incorrect motor parameter	Switch off the system completely and then back on using the LED button (28) on the battery pack (26). If the problem persists, contact your e-Bike dealer.
81	An error was detected in the data	Switch off the system completely and then back on using the LED button (28) on the battery pack (26). If the problem persists, contact your e-Bike dealer.
82	The program has been manipulated	Switch off the system completely and then back on using the LED button (28) on the battery pack (26). If the problem persists, contact your e-Bike dealer.
83	Error in program sequence	Switch off the system completely and then back on using the LED button (28) on the battery pack (26). If the problem persists, contact your e-Bike dealer.
84	Incorrect motor parameter	Switch off the system completely and then back on using the LED button (28) on the battery pack (26). If the problem persists, contact your e-Bike dealer.

Your notes

Brose Antriebstechnik GmbH & Co. KG, Berlin
Sickingenstr. 29-38
10553 Berlin
+49 30 343498 100
+49 30 343498 122
ebike.berlin@brose.com
www.brose-ebike.com